

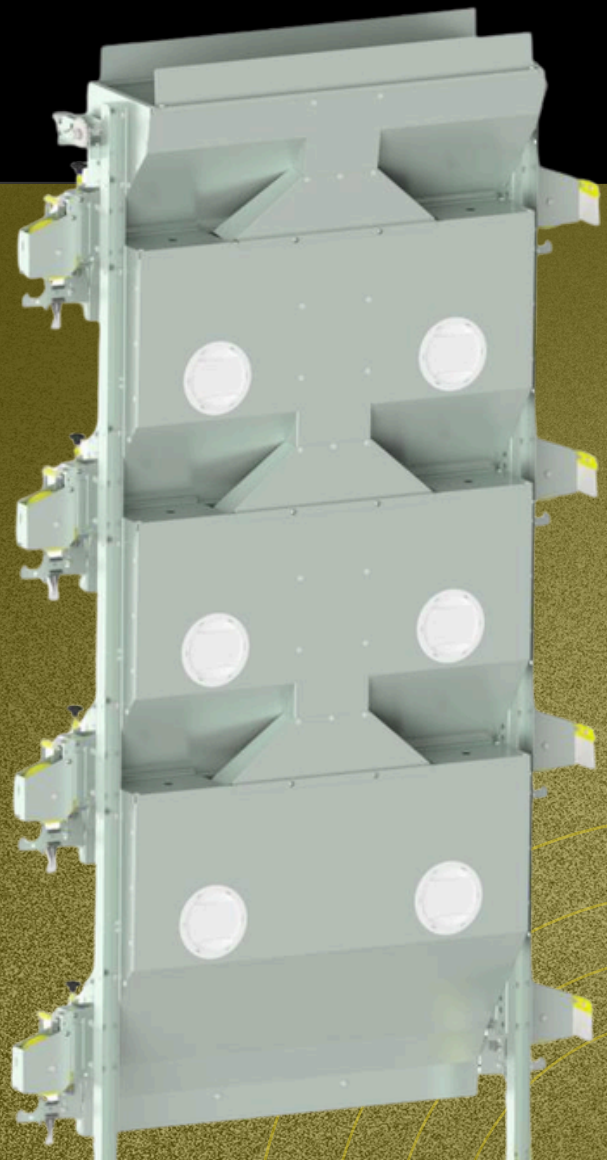

**VALLI**®

# TRAVELLING FEED HOPPER

A Clear and Simple Introduction  
to Our Product



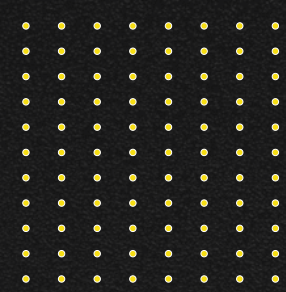

# Introduction

---



The feed hoppers ensure accurate distribution thanks to the graduated adjustment of the feed level and the option to use one or two loading hoppers per circuit, making them ideal for feeding long rows of colonies. In colony systems, the travelling feeders move along the external Valli trough, while in aviary systems, they operate within the dedicated internal trough.

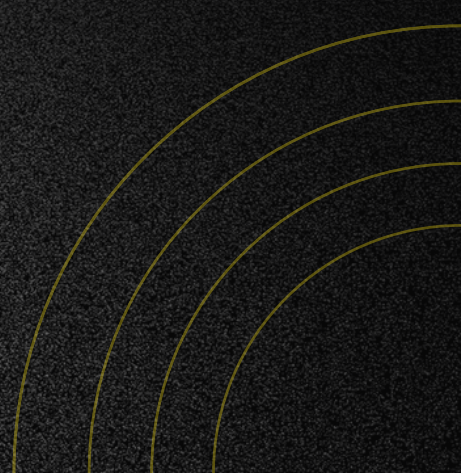

# Travelling Feed Trolley – Technical Features

## Dimensions:

The machine provides a modular installation with the following configurations:

**Length:** 1500 mm

**Height:** from minimum 1000 mm approx. and maximum 4500 mm approx.

**Width:** 260 mm

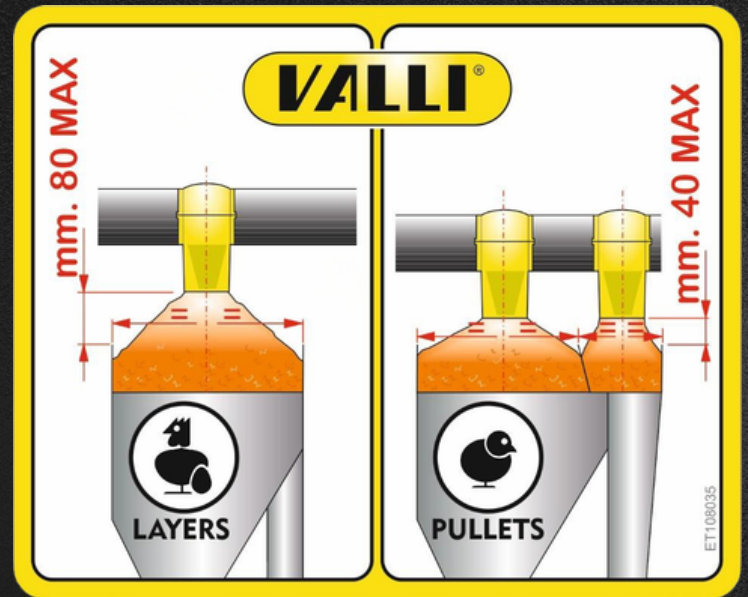

## Motors

- 0.25 kW – 50 Hz
- 0.30 kW – 60 Hz

## Standard travelling speed

- 6 – 7 m/min (19.5 – 23 ft/min)
- The system is typically equipped with two travelling feed trolleys, one on each side of the cages (left and right), running along the full length of the house and returning to ensure uniform feed distribution.
- Double motor configuration (two geared motors) is provided in the following cases:
  - Systems with  $\geq 7$  tiers
  - All Space Colony models
  - Systems with service walkway:
    - Below the walkway → always equipped with two motors
    - Above the walkway → two motors required when light bridges are installed; otherwise, a single motor configuration is possible

## Optional

- Watchdog system: sensor to detect trolley malfunction or non-operation

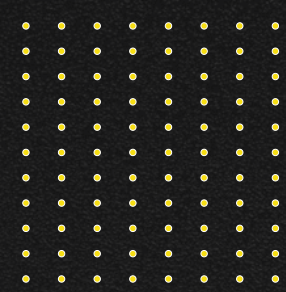

- For colony rows longer than 80 m, upper feed hoppers must be +100 mm higher;

## ➤ Technical Features

The selector allows you to select the mode of operation of the trolleys:

- **MAN:** manual handling of trolleys
- **0:** disabled carts;
- **AUTO:** automatic management of trolleys.

Through the "FEED TROLLEYS" selectors placed in the "MAN" position, the trolleys are enabled for MANUAL operation.

Using the selector "FEED CARTS" select "AUTO"

Set the chosen times for dispensing the feed.

Select the rows chosen for the dispensing of the feed through the selectors "FEED CART ROW X" by putting the selector on the "ON" position.



## Feeding Control

The hopper feeding system is controlled by a timer, allowing programming of:

- number of daily feeding cycles
- waiting time in the parking areas at the end of cage rows

# Additional Features



## Motors

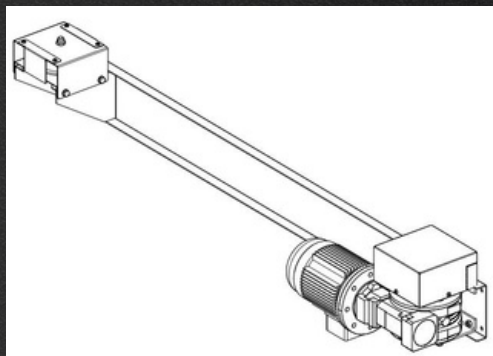

1 motor: drives both left and right feed hoppers  
2 motors: one for each side

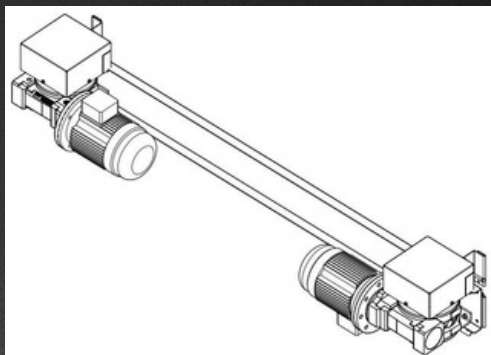

2 motors: one for each side

## Feed Level Adjustment

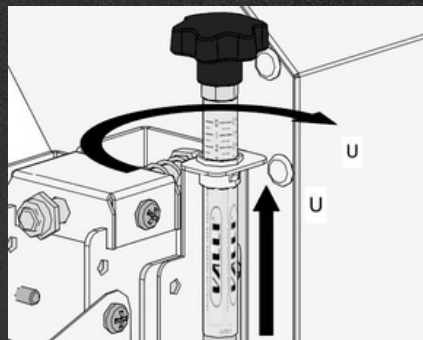

Feed level is adjusted via two screws, located at each end of the distribution shuttle, allowing precise control of the feed quantity.

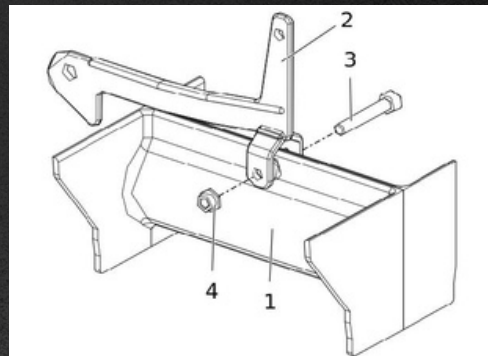

## Bip-Bip

Feed removal at parking areas  
No more food in parking area

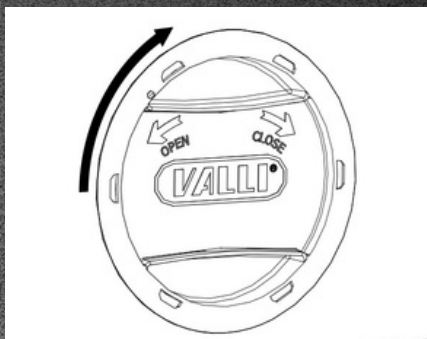

## Feed Hopper Closing

Transparent round cap installed on the feed tower side, allowing visual inspection of the feed level; removable by simple rotation.

# Feed Hopper System – Overview



The system is based on a simple and reliable concept, including feed hopper, drive unit, corners, trough and feed chain, designed to ensure efficient and uniform feed distribution.

## Key Advantages

- Independent hoppers running on the self-supporting feed trough
- Included brushes for feed trough and egg channel cleaning
- Shuttle feed dispenser for best feed distribution
- Design to avoid feed bridging or feed separation
- Available sliding feed trough-end cleaner: no feed waste
- New feed level adjustment
- Standard speed: 6-7 mts/min (19.5-23 ft/min)